

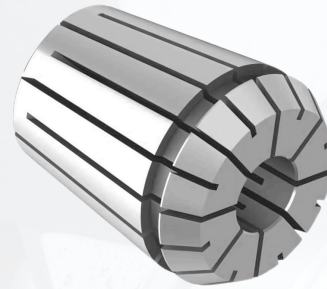

Pinzas ER - DIN 6499/B estándar

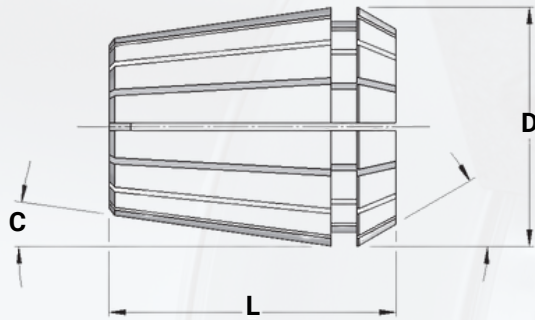

Modelo			Amarre			Medidas		
N° Art.	DIN	Tipo	Rango (mm)	Expansión	Escalonado	D	L	C
0554	4004E	ER 8	1,0 - 5,0	0,5 mm	0,5	8,5	13,5	8°
5573	4008E	ER 11	1,0 - 7,0	0,5 mm	0,5	11,5	18	8°
5601	424E	ER 12	1,0 - 3,0 3,0 - 8,0	0,5 mm 1,0 mm	0,5	12	19,5	8°
0364	426E	ER 16	1,0 - 3,0 3,0 - 10,0	0,5 mm 1,0 mm	0,5	17	27,5	8°
0787	428E	ER 20	1,0 - 3,0 3,0 - 13,0	0,5 mm 1,0 mm	0,5	21	31,5	8°
0996	430E	ER 25	1,0 - 3,0 3,0 - 16,0	0,5 mm 1,0 mm	0,5	26	34	8°
0988	470E	ER 32	2,0 - 20,0	1,0 mm	0,5	33	40	8°
0821	472E	ER 40	3,0 - 30,0	1,0 mm	0,5	41	46	8°
4055	477E	ER 50	6,0 - 34,0	1,0 mm	1,0	52	60	8°
4056	494E	ER 60	10,0 - 40,0	2,0 mm	2,0	61	60	10°